

Visit portable receiver

Buttons and controls

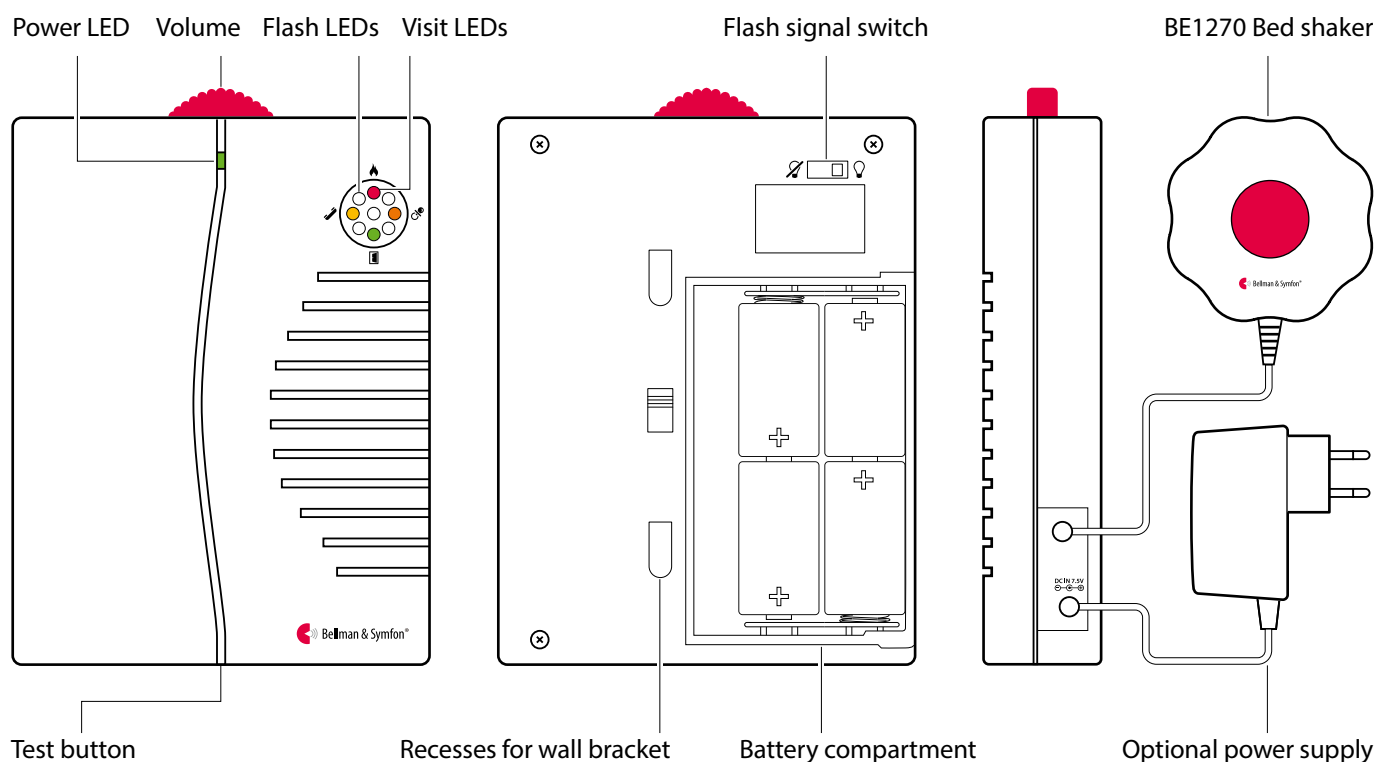

Technical specifications

In the box

- BE1450 Portable receiver
- 4 × 1.5V LR14 batteries
- Wall bracket
- Screws and wall plugs

Power and battery

- Mains power
7.5 V DC / 1500 mA
Optional power supply unit
- Battery power: 4 × 1.5 V LR14 alkaline batteries
- Operating time: 2 – 3 years with alkaline batteries
- Power consumption: Active: 1000 mA
Idle position: 0.1 mA

Environment

- Operating temperature:
0° to 35° C, 32° to 95° F
- Relative humidity: 15% to 90%, non condensing

Dimensions and weight

- Height: 165 mm, 6.5"
- Width: 130 mm, 5.1"
- Depth: 36 mm, 1.5"
- Weight: 590 g, 20.8 oz. incl. batteries

Visit LEDs

The Visit LEDs normally indicate the following:

- Orange LED, pacifier symbol
The baby monitor is activated
- Green LED, door symbol
The door transmitter is activated
- Yellow LED, telephone symbol
The phone transmitter is activated
- Red LED, fire symbol
The smoke alarm is activated
- Orange and red LEDs blink alternately
The CO alarm is activated

Output

- Adjustable sound signal
Max 93 dBA @ 1 m, frequency range: 500 – 1000 Hz
- Bed shaker outlet: 2.0 – 4.0 VDC

Frequency and coverage

- Frequency: 433.92 MHz or 868.3 MHz, depending on region
- Coverage by region:
433 MHz: 30 – 80 m (98 - 260 ft)
868 MHz: 50 – 250 m (55 - 273 yd)
Coverage depends on the radio frequency, building's characteristics and the combination of transmitters and receivers.

Accessories

- BE1270 Bed shaker
- Bellman & Symfon power supply unit for Europe or UK

Visit portable receiver

Getting started

- 1 Slide open the battery cover, fit the batteries and close the cover again.
Place the receiver on a level surface or mount it on the wall using the wall bracket.
- 2 To test the radio link you need a Visit transmitter. Press the test button/s on the transmitter.
- 3 The receiver lights up a Visit LED and starts to flash and sound. If a bed shaker is connected, it will vibrate.
A short press on the test button repeats the last indication. If nothing happens, see **Troubleshooting**.

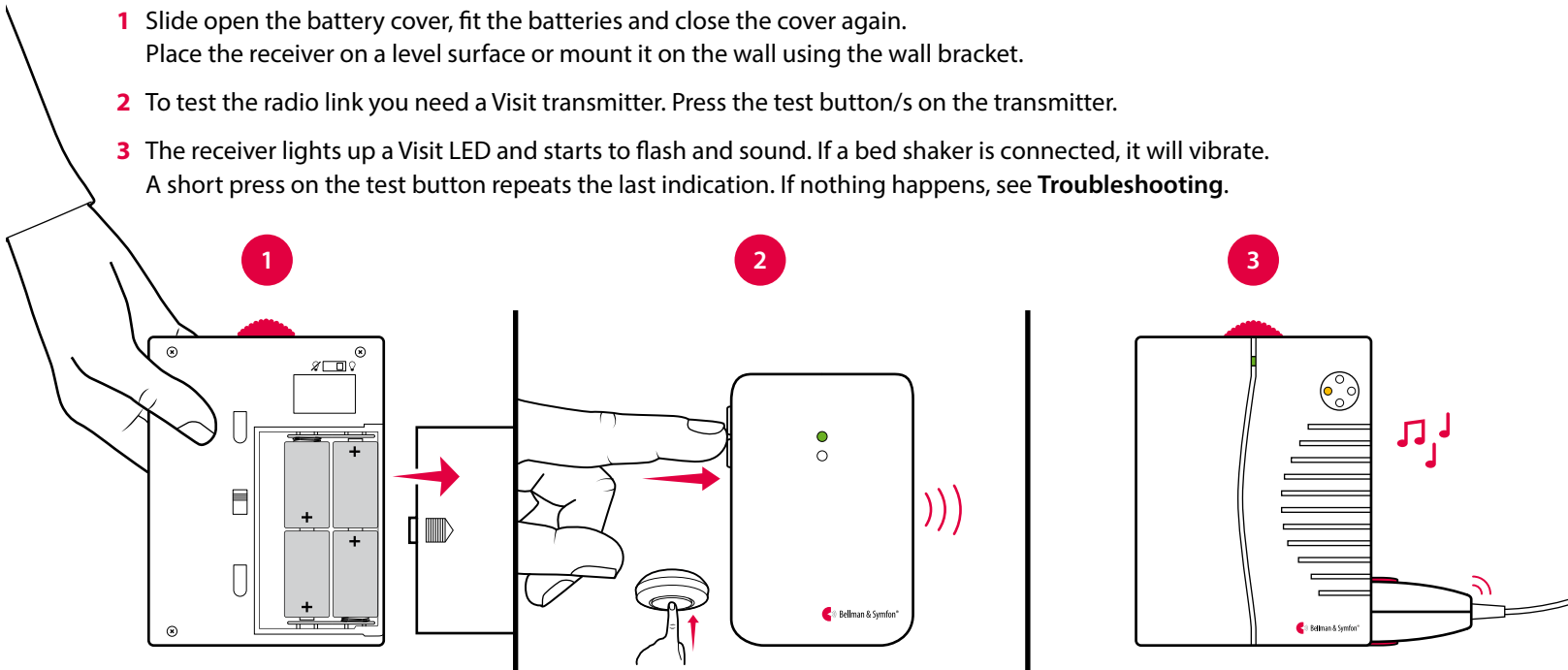

Default signal pattern

When a transmitter is activated, the receiver lights up an LED, sounds, flashes and the bed shaker starts to vibrate with a certain pace. This is called signal pattern. The transmitters determine the pattern, and the default is as follows:

Transmitter	Portable receiver			Bed shaker
Activated source	Visit LED	Sound	Flash	Vibration
■ Door transmitter / push button transmitter	Green	Door chime	Yes	Slow ■ □ □ □
■ Telephone transmitter	Yellow	Ring signal	Yes	Medium ■ ■ □ □
■ Baby monitor	Orange	Baby melody	Yes	Fast ■ ■ ■ ■ □ □
■ Smoke alarm	Red	Fire horn	Yes	Long ■ ■ □ □
■ CO alarm	Orange and red	Emergency alert	Yes	Long ■ ■ □ □

Changing the signal pattern

The signal pattern can only be changed on the transmitters. See **Changing the signal pattern** for the relevant transmitter.

Adjusting the volume and flash

Adjust the volume to your liking using the red volume dial on the top of the receiver. It goes from 0 to 93 dBA @ 1 m with a main frequency range of 500 – 1000 Hz. Use the flash signal switch on the back of the receiver to turn the flash off/on.

Replacing batteries

If the power LED is yellow when the receiver is activated, the batteries are nearly depleted. Here is how you replace them:

- Slide open the battery cover. Replace the old batteries with four new 1.5 V LR14 alkaline batteries, see the battery compartment for correct positioning.

Visit portable receiver

Changing the radio key

If your Visit system is activated for no reason, there is probably a nearby system that triggers yours. In order to avoid radio interference, you need to change the radio key on all units. The radio key switches are located on the **transmitters**.

Here is how you change the radio key:

- 1 Open the transmitter cover and move any radio key switch to the up (on position) to change the radio key. See **Changing the radio key** for the relevant transmitter.
- 2 Press and hold the test button located on the bottom of the portable receiver until the green and yellow Visit LEDs blink alternately. Release the button.
- 3 Press the test button/s on the transmitter within 30 seconds to send the new radio key.
- 4 All Visit LEDs on the receiver blink 5 times to show that the radio key has been changed. It then returns to normal mode.

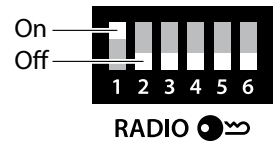

Note: All Visit units must be set to the same radio key in order to operate as a group.

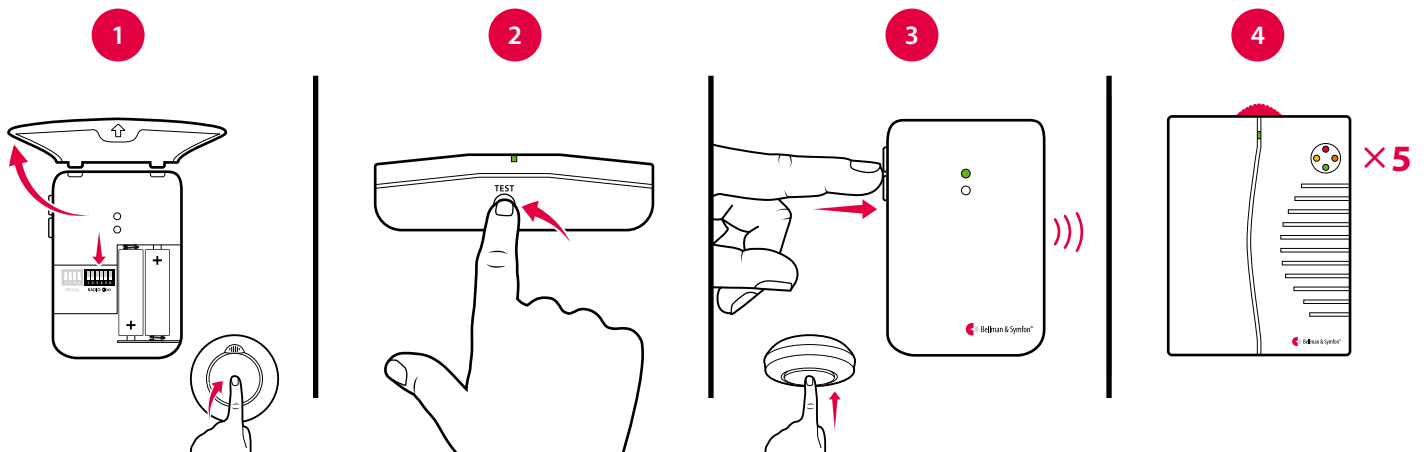

Accessories

The portable receiver can be complemented with the following accessories:

- **BE1270 Bed shaker**

Wakes you with vibrations if anything happens while you are asleep. Connect it to the receiver and slide it under your pillow or mattress.

- **Bellman & Symfon Power supply unit for Europe or UK**

If your receiver has a fixed place, you can connect it to mains power and not have to worry about batteries.

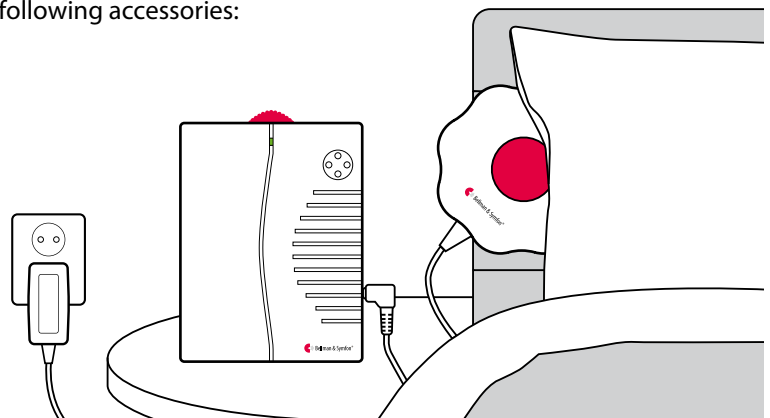

Visit portable receiver

Advanced programming

By using advanced programming, you can customize the signal pattern from a specific transmitter and event, displaying the LED color, sound and vibration pattern of your choice. The advanced programming overrides the radio key and pairs the units via the serial number. Please note that smoke alarms cannot be programmed for safety reasons.

Note: The transmitter must be activated as it is intended to be used in the system to generate the right signal. This means that you can't always use the transmitter test button (see **Default signal pattern** for the relevant transmitter).

Here is how you program the receiver:

- 1 Press and hold the test button on the receiver. The green and yellow Visit LEDs will start to blink alternately. While still holding down the button, activate the desired transmitter as intended. The power LED on the receiver will light up in yellow to show that you are in advanced programming mode. Release the button.
- 2 Scroll through the different **Visit LED options** by pressing the test button on the receiver. Select the desired Visit LED color by holding down the test button until the power LED goes out and lights up again.
- 3 Scroll through the different **sound options** by pressing the test button on the receiver. Select the desired sound by holding down the test button until the power LED goes out and lights up again.
- 4 Scroll through the different **vibration options** by pressing the test button on the receiver (bed shaker required). Select the desired vibration pattern by holding down the test button until the power LED goes out and lights up again.
- 5 The receiver will now show the new Visit LED color, sound and vibration pattern. Press the test button briefly to end the demonstration. After a short while, it will return to normal mode.

Deleting the advanced programming

Follow the procedure below to delete the advanced programming.

- 1 Hold down the test button on the receiver until the green and yellow Visit LEDs blink alternately. Release the button.
- 2 Press the test button on the receiver 3 times in quick succession.
- 3 All Visit LEDs will light up for ~2 seconds to show that it has been deleted.

Troubleshooting

If	Try this
The receiver seems to be turned off	<ul style="list-style-type: none"> ▪ The batteries are depleted. Replace them with 4 × 1.5V LR14 alkaline batteries.
The power LED is yellow when the receiver is activated.	<ul style="list-style-type: none"> ▪ The battery level is low. Replace them with 4 × 1.5V LR14 alkaline batteries.
The receiver does not respond when a transmitter is activated, but works when I use the test button	<ul style="list-style-type: none"> ▪ Check the transmitter batteries and connections. ▪ Move the receiver closer to the transmitter to make sure it's within radio range. ▪ Check that the receiver is set to the same radio key as the other units in the Visit system, see Changing the radio key.
The receiver is activated for no apparent reason	<ul style="list-style-type: none"> ▪ There is probably another Visit system installed nearby that triggers your system. Change the radio key on all units, see Changing the radio key.
The receiver is too quiet	<ul style="list-style-type: none"> ▪ Turn up the volume using the red volume dial on the top of the unit.
The receiver is not flashing	<ul style="list-style-type: none"> ▪ Check that the flash signal switch on the back of the unit is set to the ON position.